



Using the **Gyratory Pressure Distribution Analyzer -GPDA** to Estimate Compaction Resistance

Hussain Bahia and Andrew Hanz
University of Wisconsin - Madison

Warm Mix Technical Working Group Meeting
May 18, 2010, Auburn, AL

Background- Problem Statement & Hypothesis

- **Best mixture design should include:**
 - Volumetrics
 - resistance to compaction for construction, and
 - performance testing for traffic/climate
- **Difficulty:**
 - No current system for compaction resistance
 - Current performance testing is not practical for Quality Control and Quality Assurance.
- ***Can the SGC be used to address both?***
 - Compactive Effort - *Workability*
 - Aggregate Interlock - *Stability*

History of using the Gyratory to estimate shear resistance

- **McRae** – Gyratory Testing Machine
 - 1960's and 1970's
- **Goetz, Ruth, and others** recommended using GTM for mix design to measure stability
 - 1980's and 1990's
- **France, Australia, and Finland** have used the Gyratory for mixture evaluation
 - 1980's and 1990's
- *In 1993 the **Superpave Gyratory Compactor** was adopted in the U.S.*

Better Utilization of SGC

Since 1996-Not a new topic

- **1996:** Use **densification slope**
 - Relationship to Mixture G^*
- **1998:** Use **densification curves** to define
 - Resistance to compaction
 - Resistance to traffic
- **2000:** Use gyratory with **GLPA to measure shear** between aggregates
 - Resistance to compaction & to traffic
- **2002:** NCHRP **9-16** (M. Anderson et al.)
 - **Gyrations at maximum stress** relate to field rutting

Superpave Volumetric Design Criteria

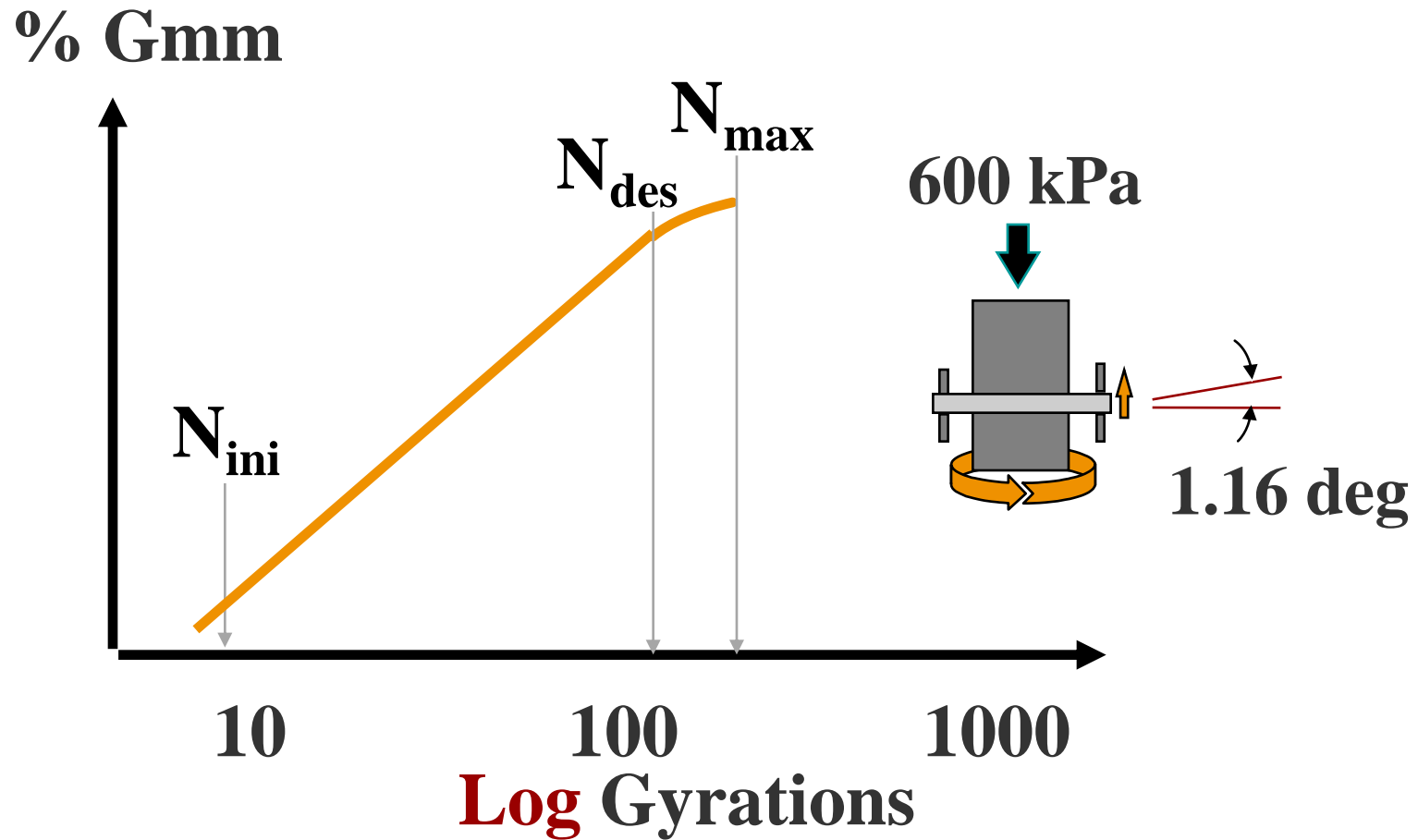

Schematic - Force Indices

Construction

- CFI
- N_{ini} to 92%
- G_{mm}

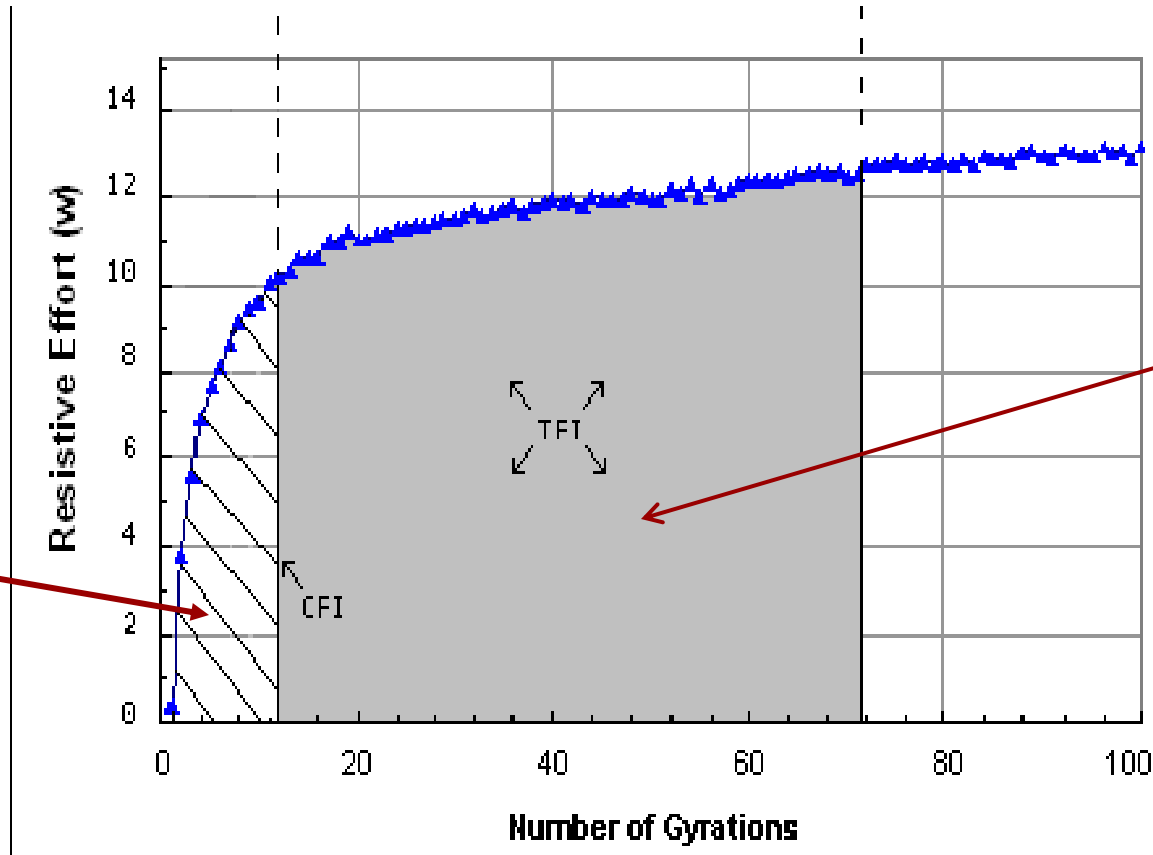

Traffic

- TFI
- 92% - 98%
- G_{mm}

HMA Basics: Rocks + Asphalt + Air Voids

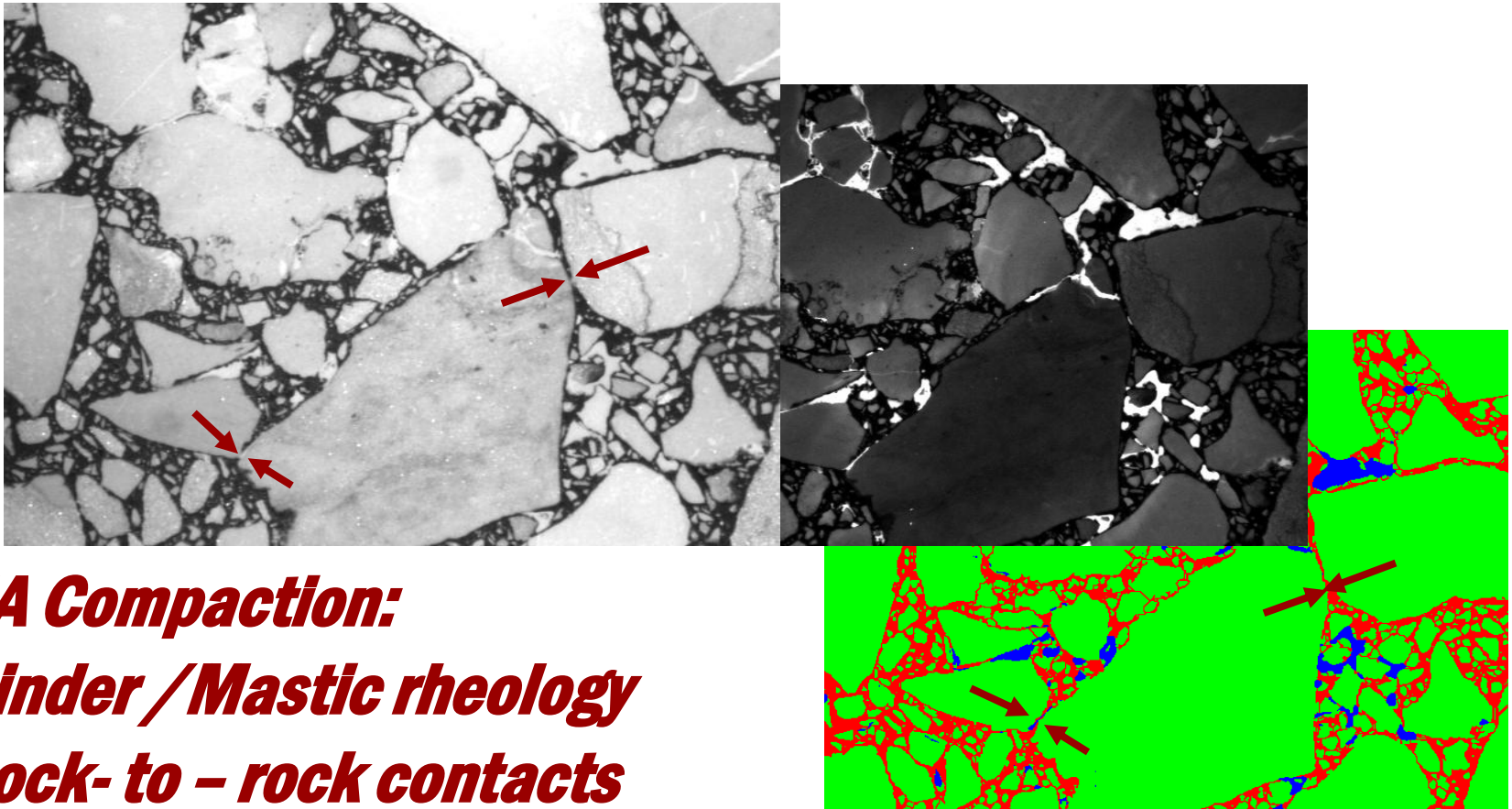

HMA Compaction:
1. Binder / Mastic rheology
2. Rock- to - rock contacts

What actually happens in the Superpave Gyrotory Compactor?

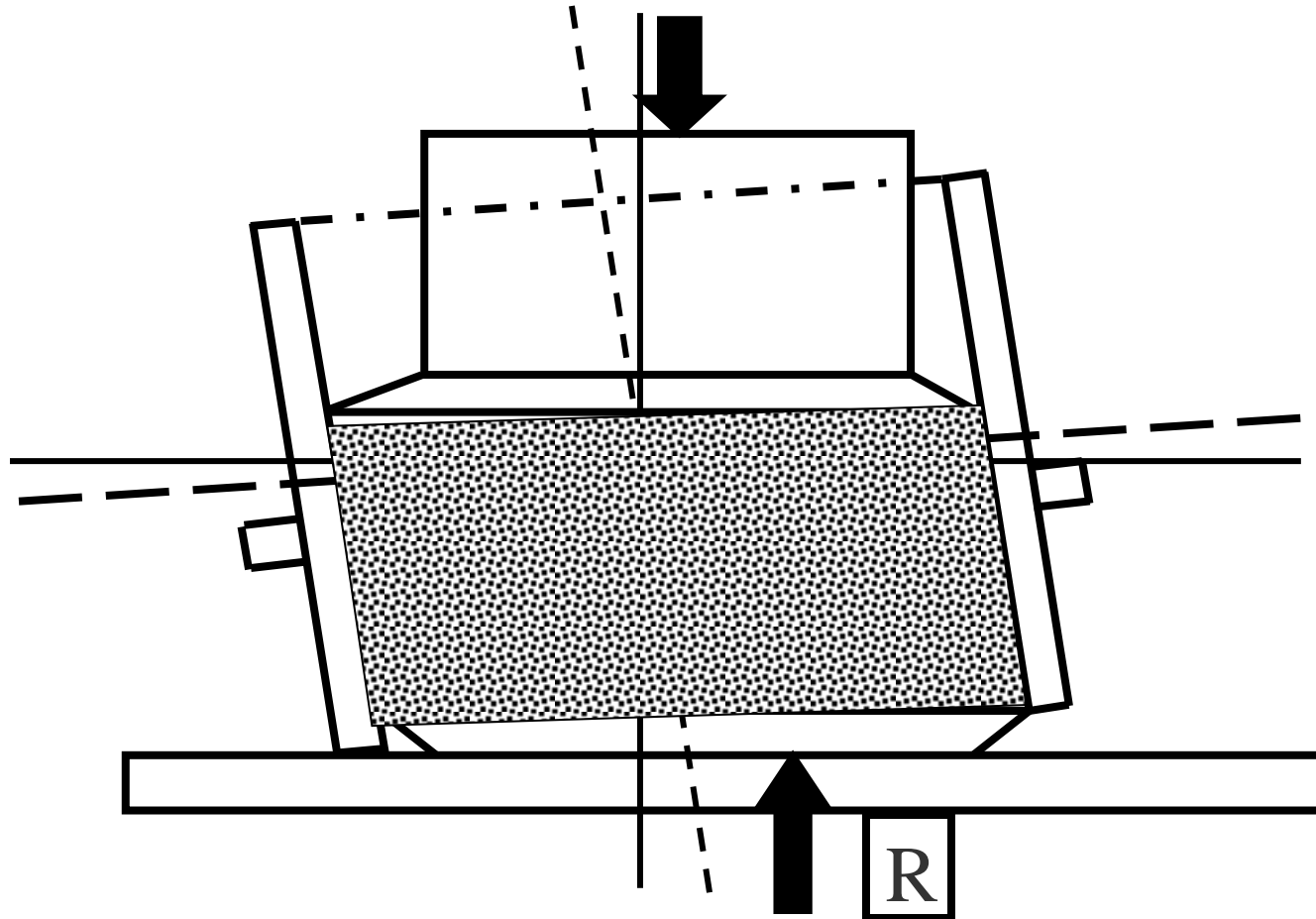

Example 1: Behavior of a “Good Mix”

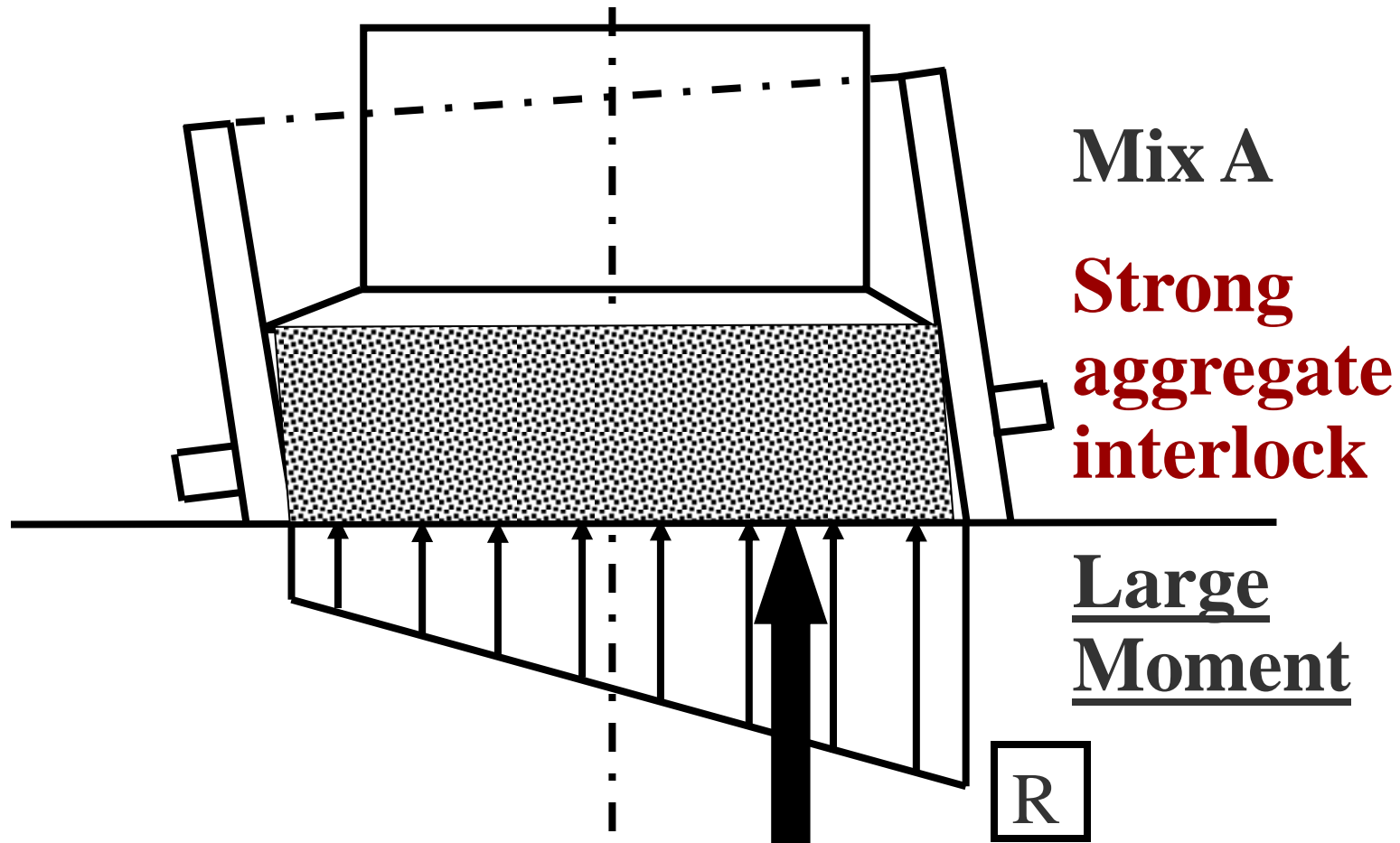

Example 2: Behavior of a “Bad Mix”

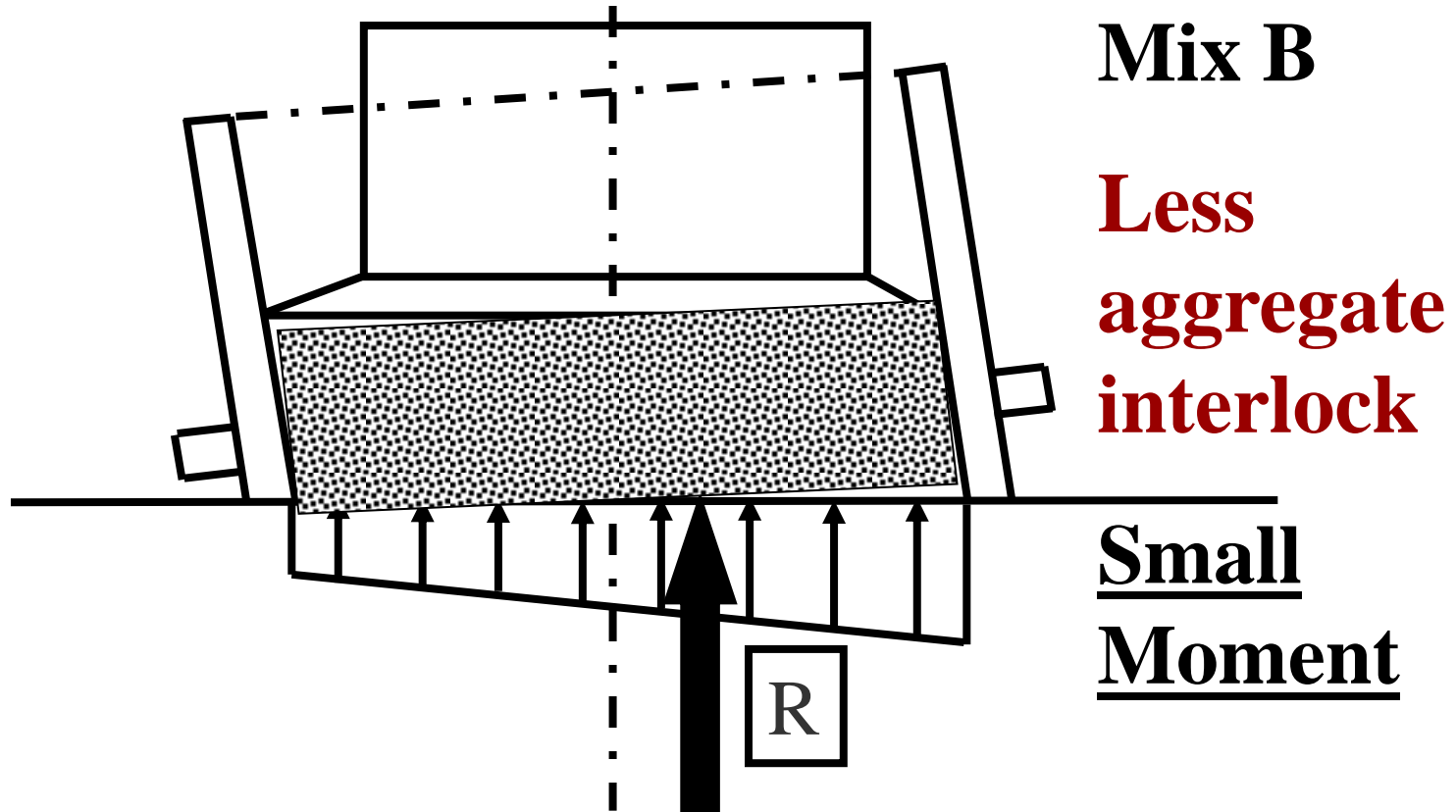

Use of the Shear Plate (GPDA) to Calculate Eccentricity (e) of Resultant load (R)

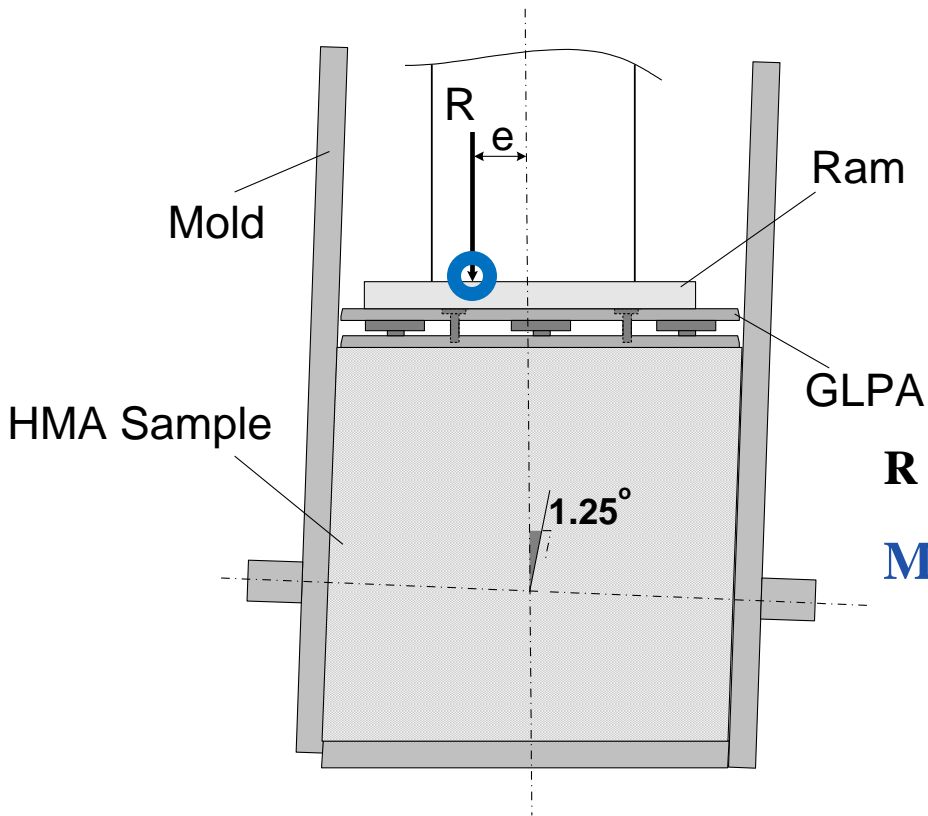

$$\mathbf{R} = \mathbf{P}_1 + \mathbf{P}_2 + \mathbf{P}_3$$

$$\mathbf{M}(t) = \mathbf{R} * \mathbf{e}(t)$$

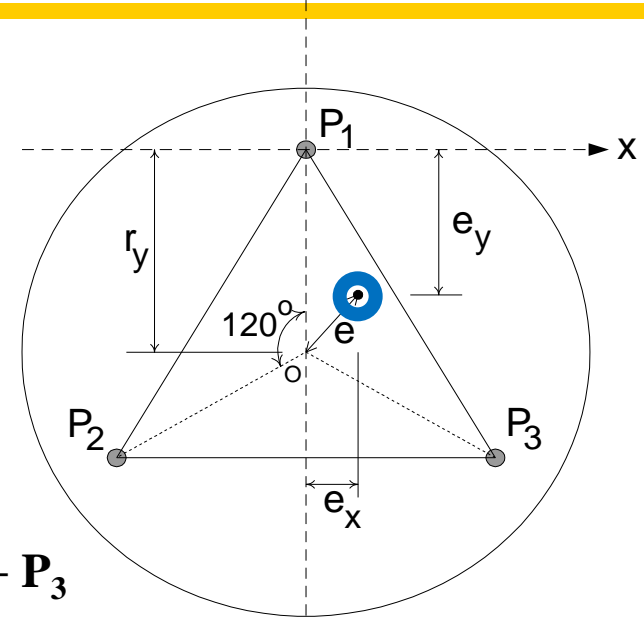

$$\sum M_x = 0 \Rightarrow e_y$$

$$\sum M_y = 0 \Rightarrow e_x$$

$$e = \sqrt{e_x^2 + (r_y - e_y)^2}$$

GPDA Used in the SGC Compaction Mold



Sample of Collected Data and Typical Analysis

*2D Eccentricity plots for HV2 and HV5 samples
at 6.5 % asphalt content*

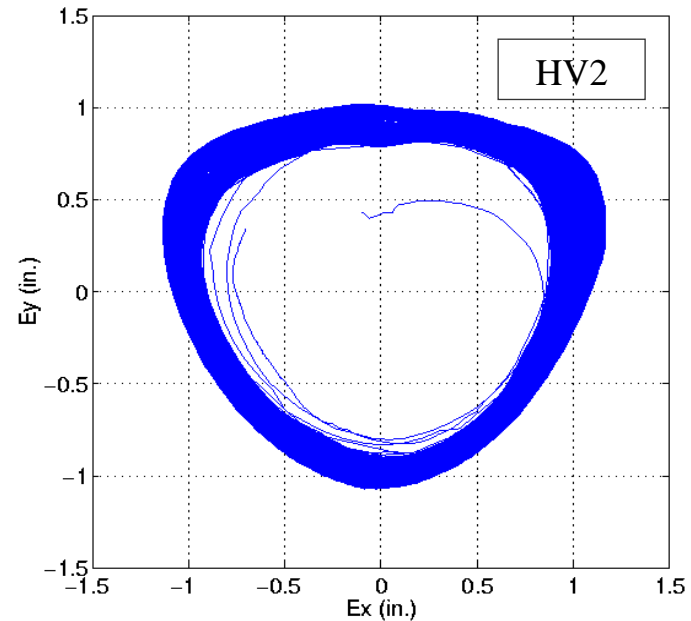
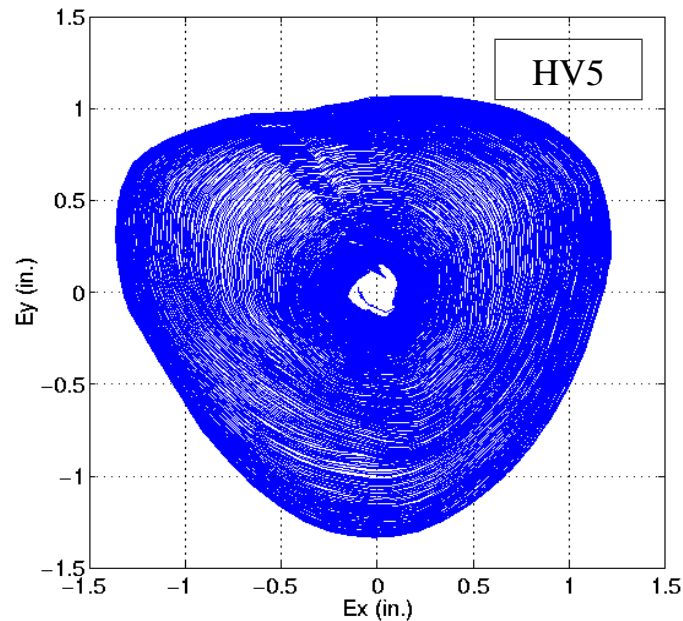

Sample of Collected Data and Typical Analysis Cond't

3D Plots for HV2, HV5 (at 6.5% asp. content)

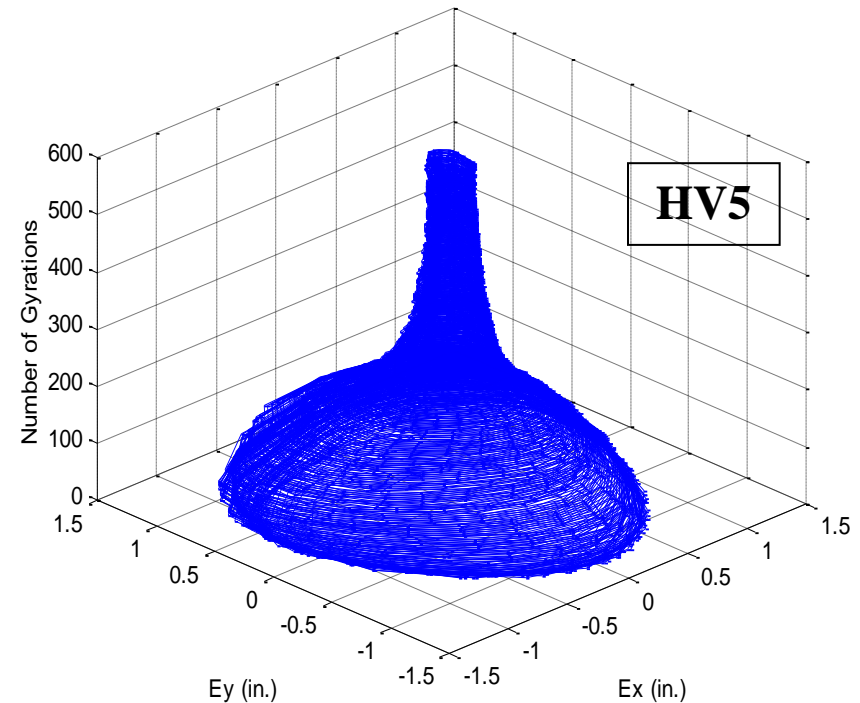
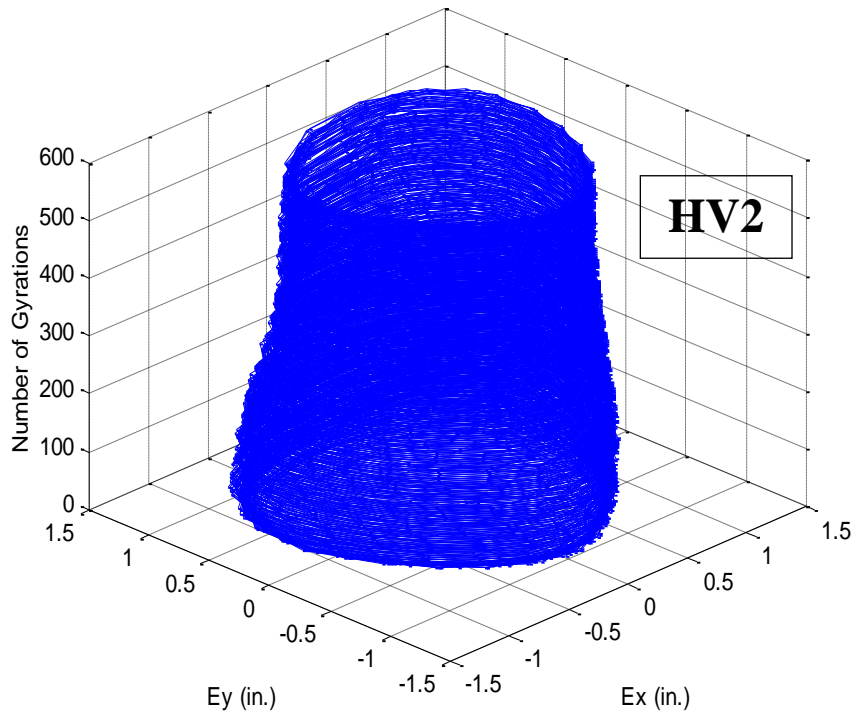

Sample of Collected Data and Typical Analysis cond't

Load Cell force distributions versus number of gyrations for HV2 and HV5 mixtures

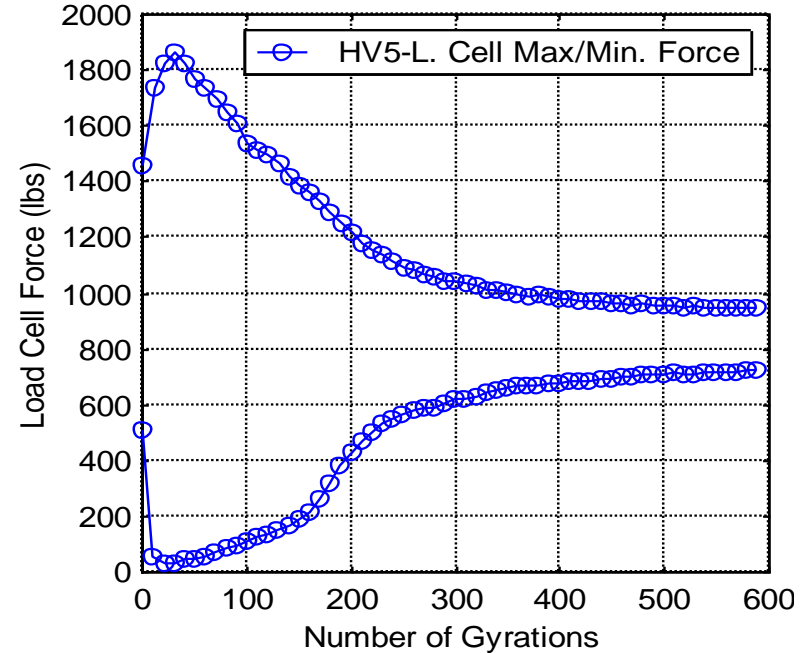
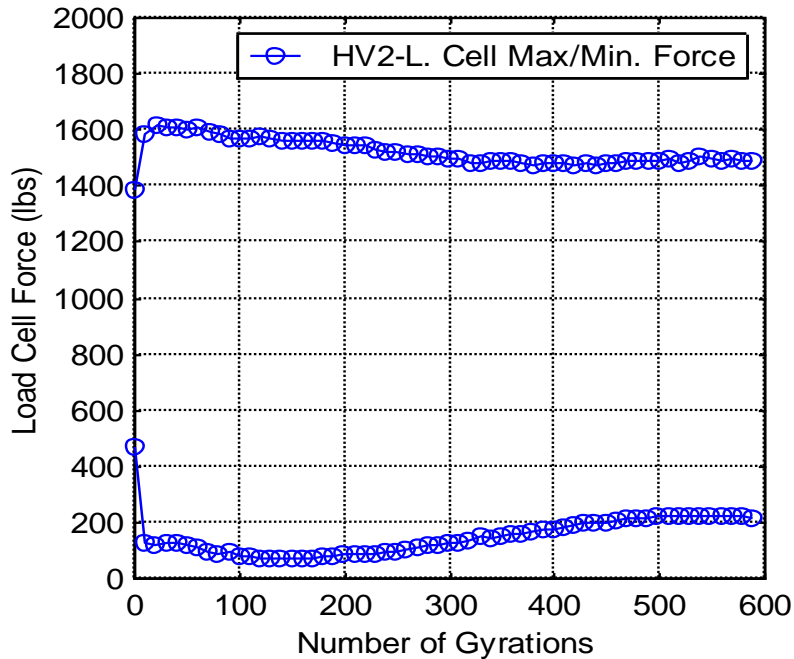

Sample of Collected Data and Typical Analysis cont'd

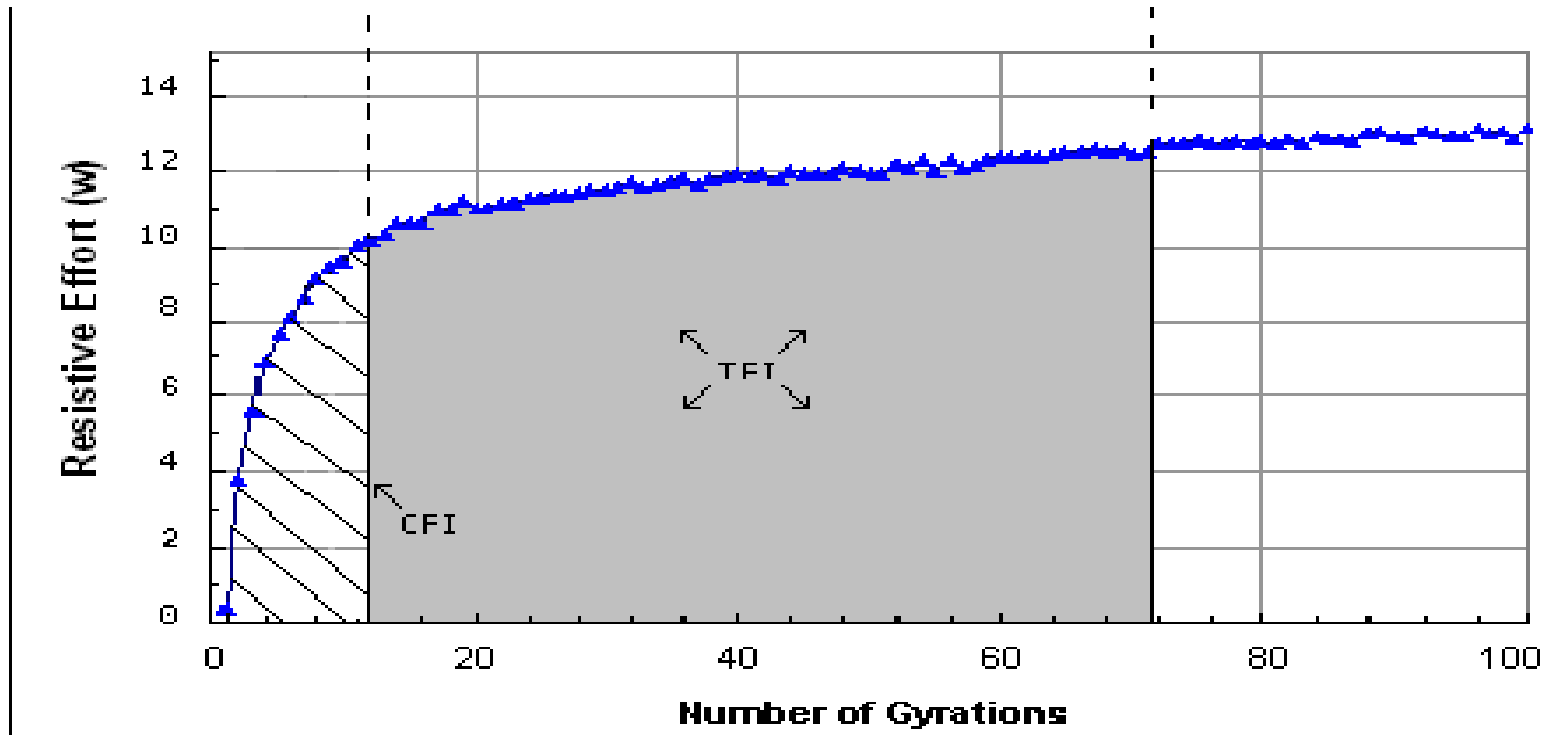

Combine force measurements and volumetrics to calculate workability and stability indices.

The Resistive Effort (w)

$$w = \frac{4eP\theta}{Ah}$$

- Where

- w : the resistive effort (kPa)
- e : the eccentricity of resultant force (m)
- P : the magnitude of resultant force (kN)
- θ : the angle of tilting (1.16°)
- A : the area of specimen (m^2)
- h : the height of specimen at any given gyration (m)

Stress Analysis: Masad et al

$$S_{\theta} = (N_2 - N_1) \cos \theta + \frac{1}{2} (p_{av} - W_d) \tan \theta$$

$$du = dv + ds$$

dv = volume change energy

ds = shear change energy

$$CEI = \sum_{N_{G1}}^{N_{G2}} S_{N\theta} d_e$$

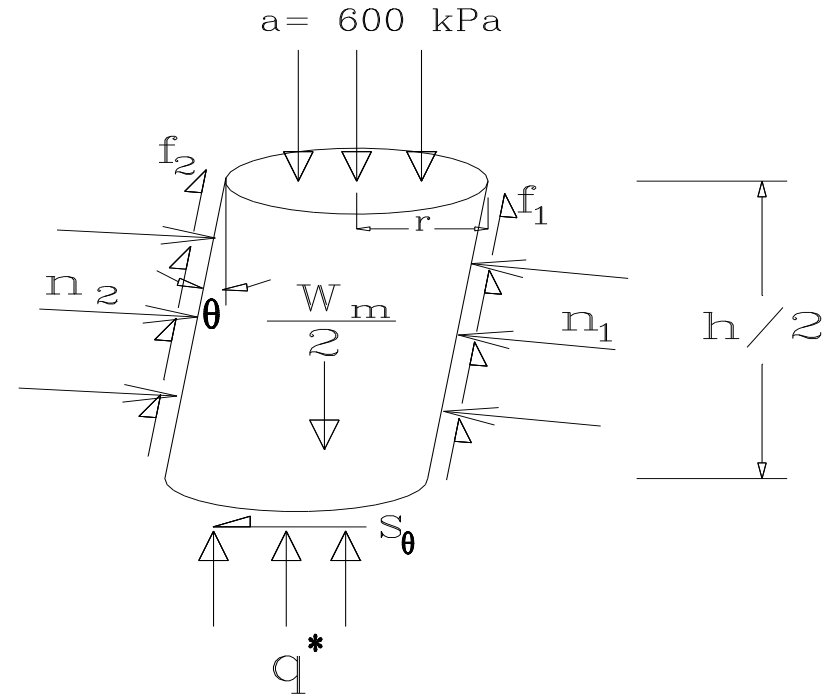

Masad, et al. "Quantifying Laboratory Compaction Effects on the Internal Structure of Asphalt Concrete." Transportation Research Record 1681. Transportation Research Board of the National Academies. Washington D.C., pp 179-185, 1999.

Comparing Mixes: Volumetrics vs. GPDA

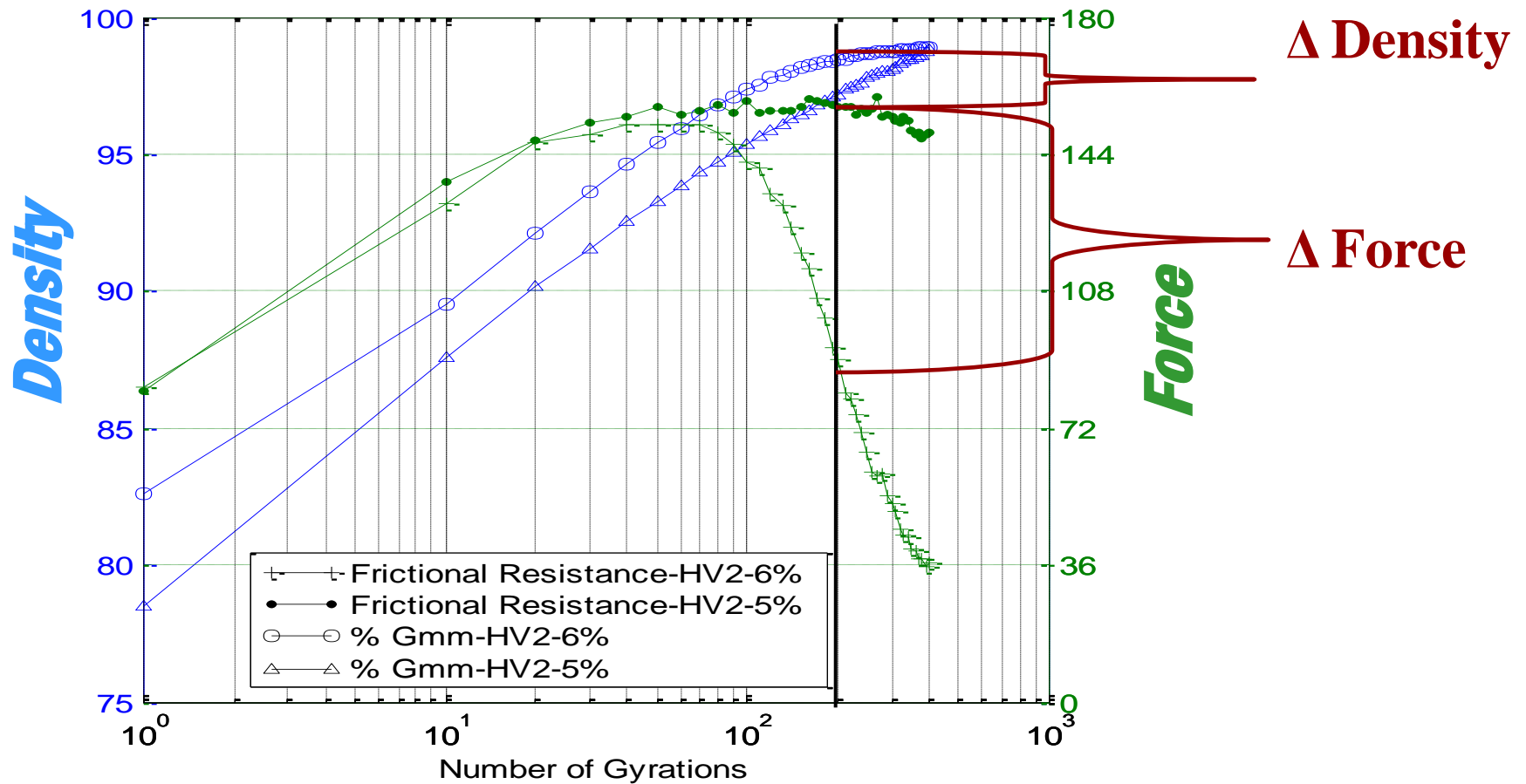

Experimental Program

- **Exp. #1**
 - Four sources of Aggregates
 - Two gradations
 - Various levels of fine aggregate angularity
- **Exp. #2**
 - Two Gradations
 - WMA additives : Revix, Rediset, VR
 - Two pressures: 600 KPa & 300KPa
- **Used GPDA to collect shear data**

Experimental Plan

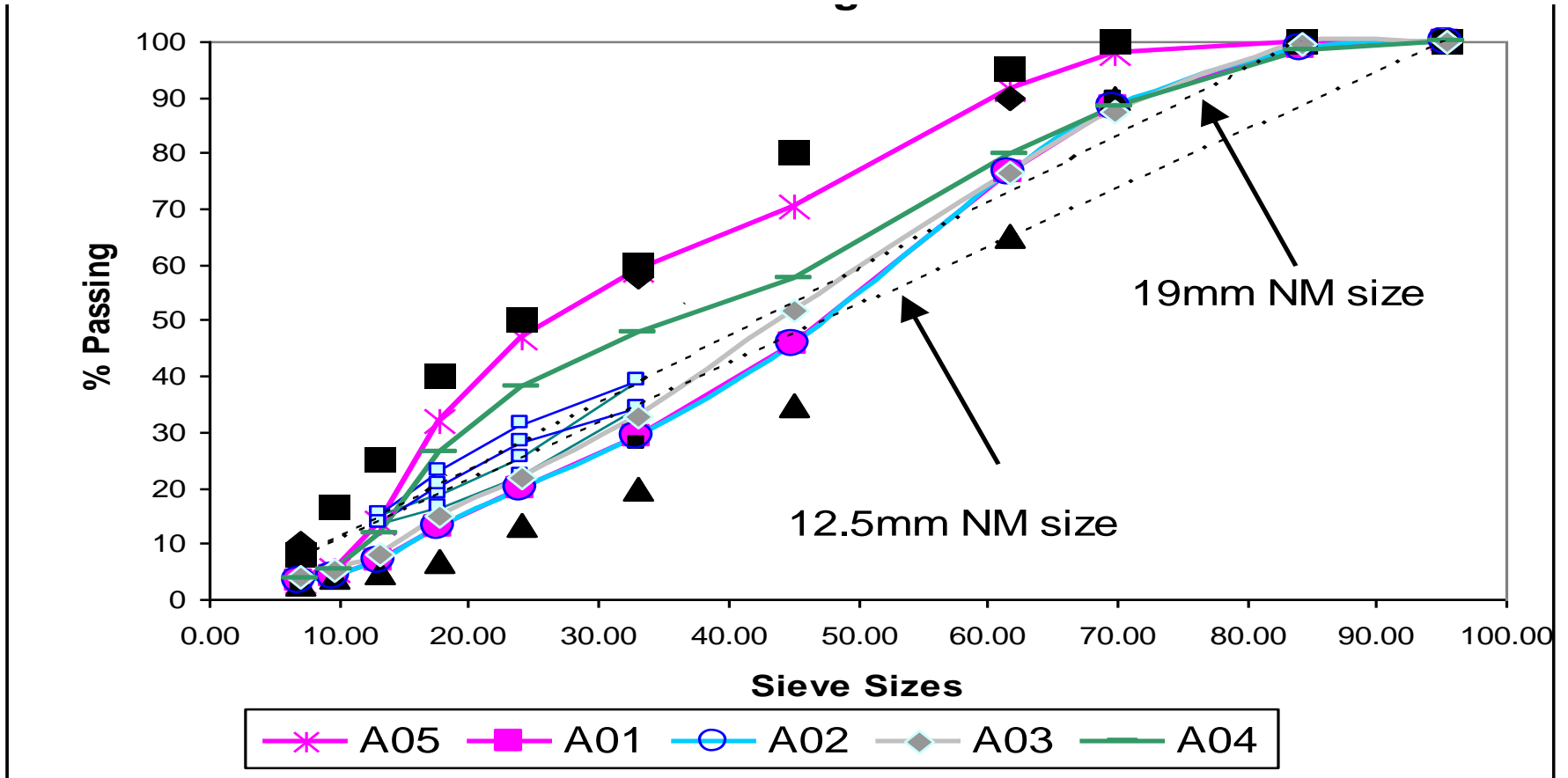

Results- Construction (CFI)

Using the GPDA (2 gyrations - 92% Gmm)

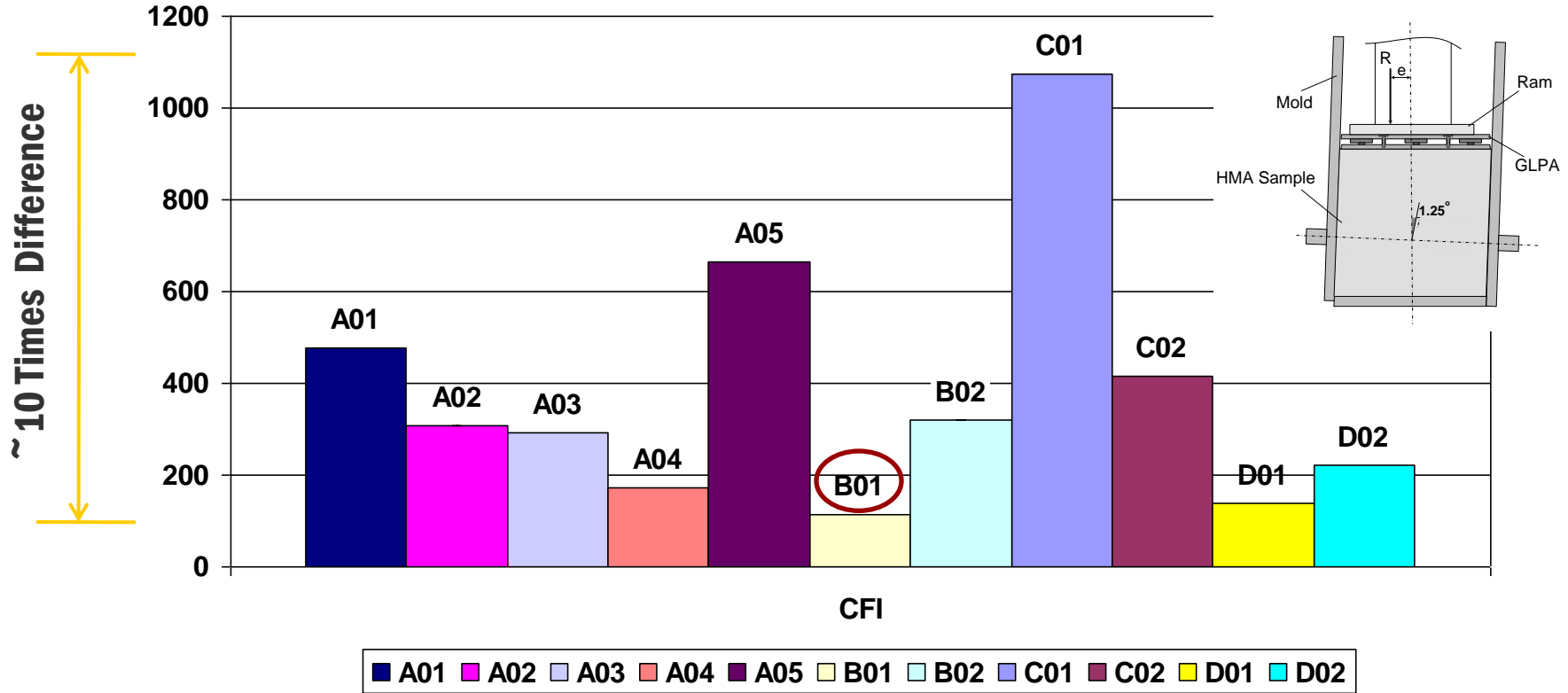

Average CFI values for all mixes

Measuring Traffic Resistance Index (TFI) with the GPDA (92% - 98% Gmm)

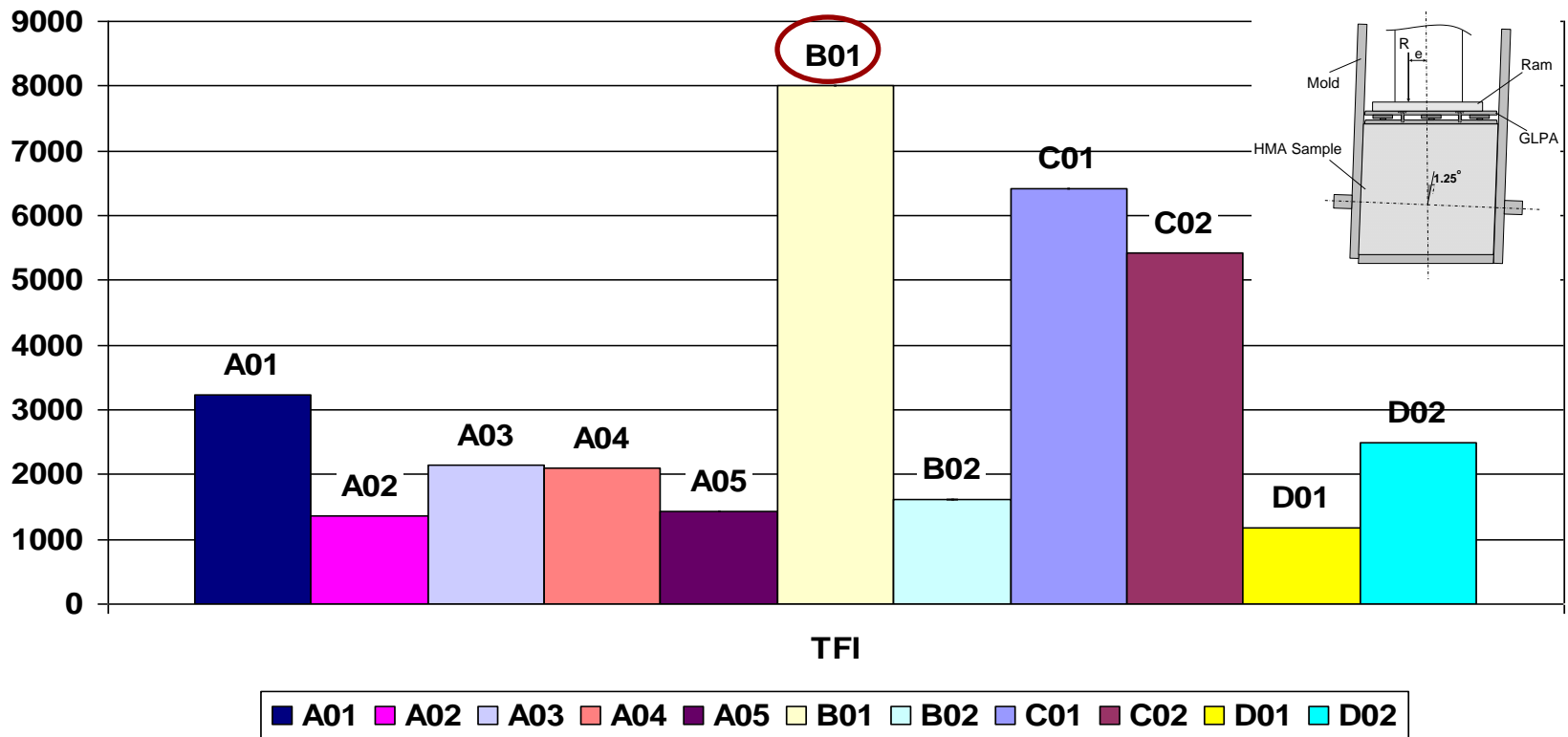

Average TFI values for all mixes

Warm Mix Asphalt Measurements

- **One SBS modified Binder**
 - PG 79-24
- **Three additives**
 - Rediset
 - Revix
 - Viscosity Reducer
- **Two Pressures**
- **Two Gradations**
- **Measured:**
 - % Gmm
 - CFI
 - 160 Gyration

Compaction Curves

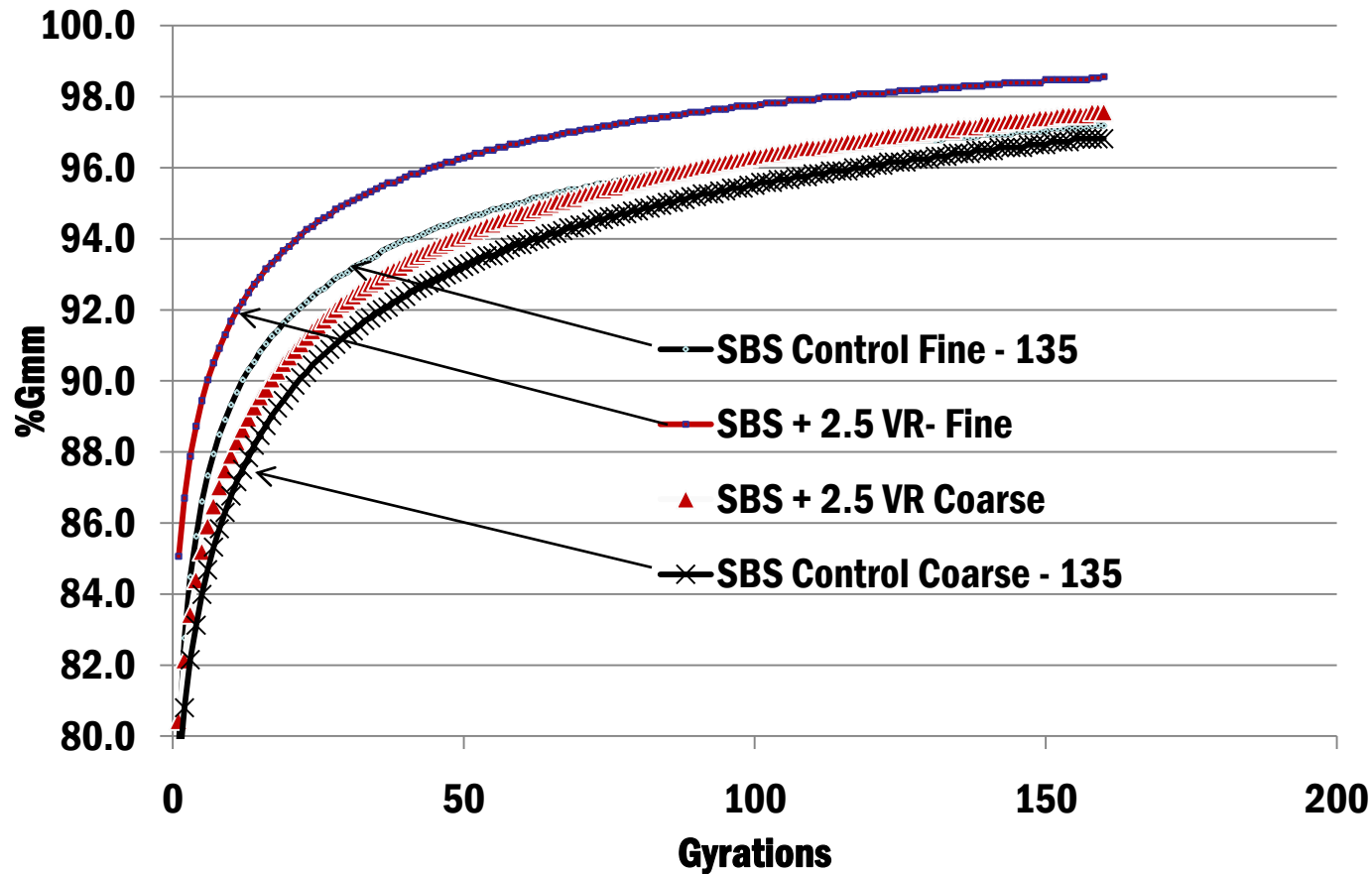

GPDA can detect effect of WMA additives

Also, change in binder content (AC)

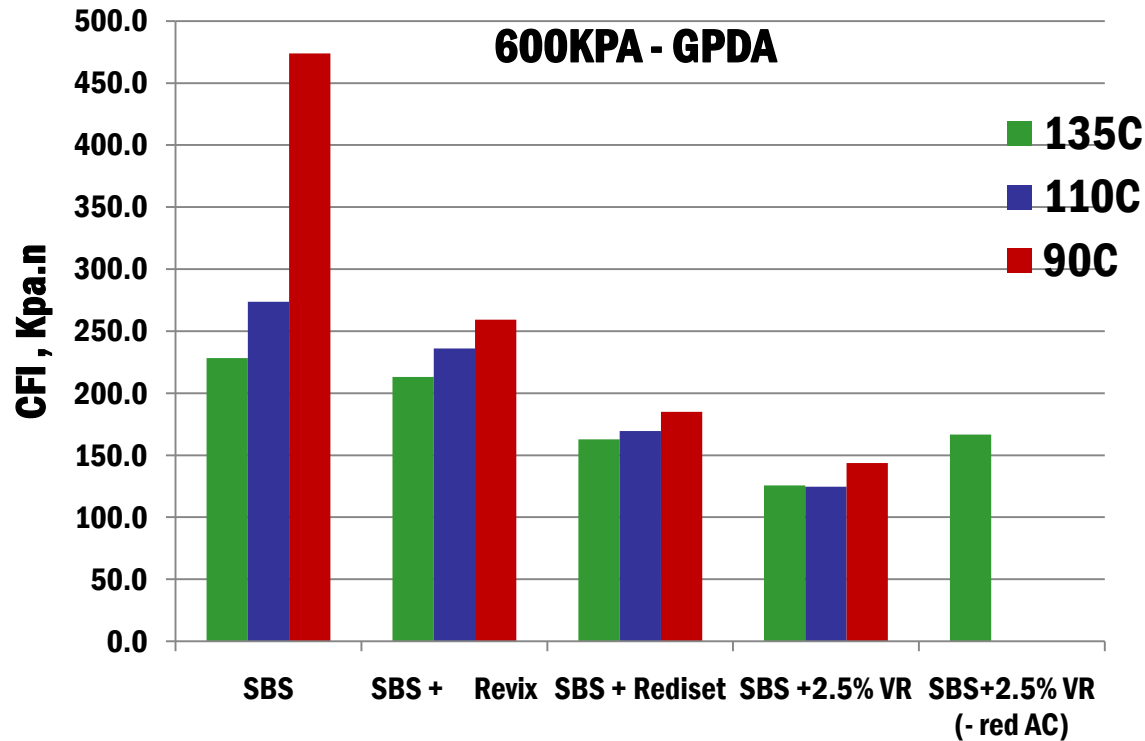

GPDA at 300KPa in SGC

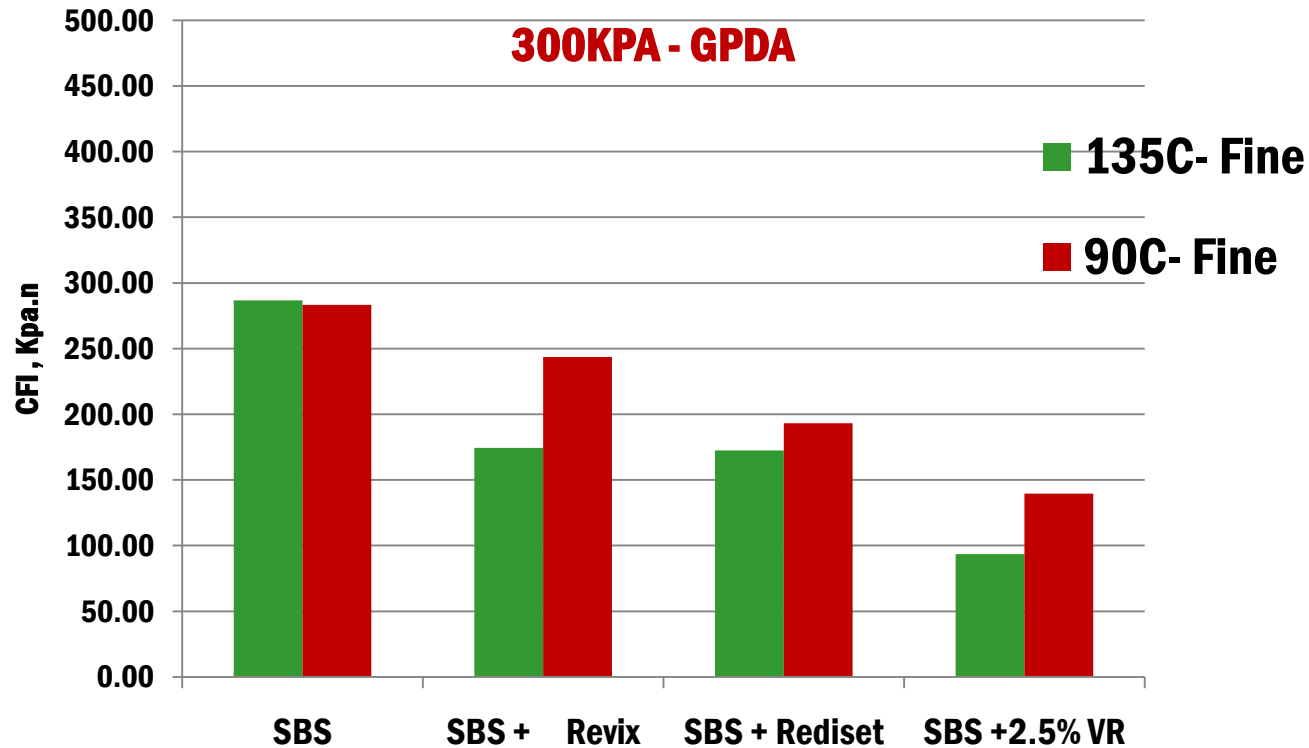

Proposed Criteria – Wisconsin DOT (2006)

Workability

Mixture Type	Traffic Level (Million ESALS)	<u>Maximum</u> CFI
E-3	<3	250
E-10	3 to <10	300
E-30	10 to <30	400

Stability

Mixture Type	Traffic Level (Million ESALS)	<u>Minimum</u> TFI
E-3	<3	800
E-10	3 to <10	1000
E-30	10 to <30	1600

ASTM Standard Under Review



Designation: D xxxx - xx

Standard Test Method for Asphalt Mixture Shear Measurement by the Gyrotory Pressure Distribution Analyzer– GPDA Method¹

This standard is issued under the fixed designation D xxxx; the number immediately following the designation indicates the year of original adoption or, in the case of revision, the year of last revision. A number in parentheses indicates the year of last reapproval. A superscript epsilon (ϵ) indicates an editorial change since the last revision or reapproval.

1. Scope

- 1.1 This test method uses the Gyrotory Pressure Distribution Analyzer (GPDA) Plate to measure the resistive forces of a bituminous mixture during compaction as a means to estimate mixture workability and stability.
- 1.2 The values given in SI units are to be regarded as standard. No other units of measurements are included in this standard
- 1.3 This standard does not purport to address all of the safety concerns, if any, associated with its use. It is the responsibility of the user of this standard to establish appropriate safety and health practices and determine the applicability of regulatory limitations prior to use.

Recommendations

- The SGC with the GPDA be used as a tool for mixtures:
 - Evaluate effect of gradation and WMA additives–
Workability
 - Estimate rutting resistance - **Stability**
- It is recommended that
 - **Workability** and **Stability** be included in evaluation of mix designs to allow for optimum mix design.
 - Conduct performance testing when possible.

Concluding Remarks

- **Density is not sufficient for QC/QA.**
- There is **no substitute for performance testing** of asphalt mixtures. However current tests are hardly suitable for QC/QA.
- **GPDA in the SGC can be used to study**
 - reduce possible combinations of mixture variables
 - Workability – Compaction effort - **Warm Mix**
 - Stability – **Gradation**
 - conduct more reliable QC/QA

Effects of Warm Mix Additives on Workability (CFI)

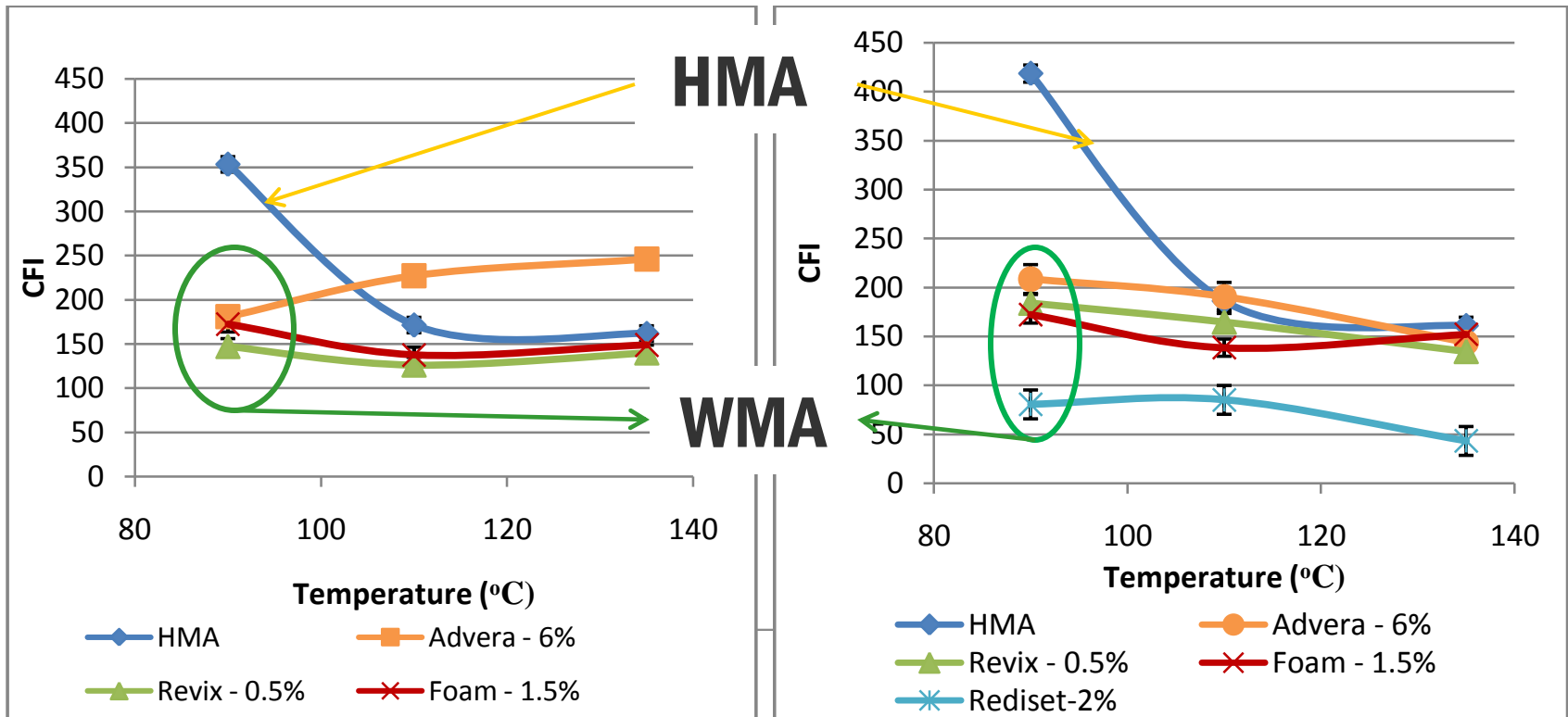

PG 64-22

PG 76-22